

Punchdown manway:
fully welded into the truncated conical top,
allows for easy access into the tank for
punchdown, inspection, and service.

Zero pressure/vacuum break,
prevents any pressure or vacuum
buildup inside of the tank

Energy saving precision laser welded dimple cooling jackets,
engineered to maximize turbulence and minimize load on
the glycol cooling system, low and high pressure options
available for glycol.

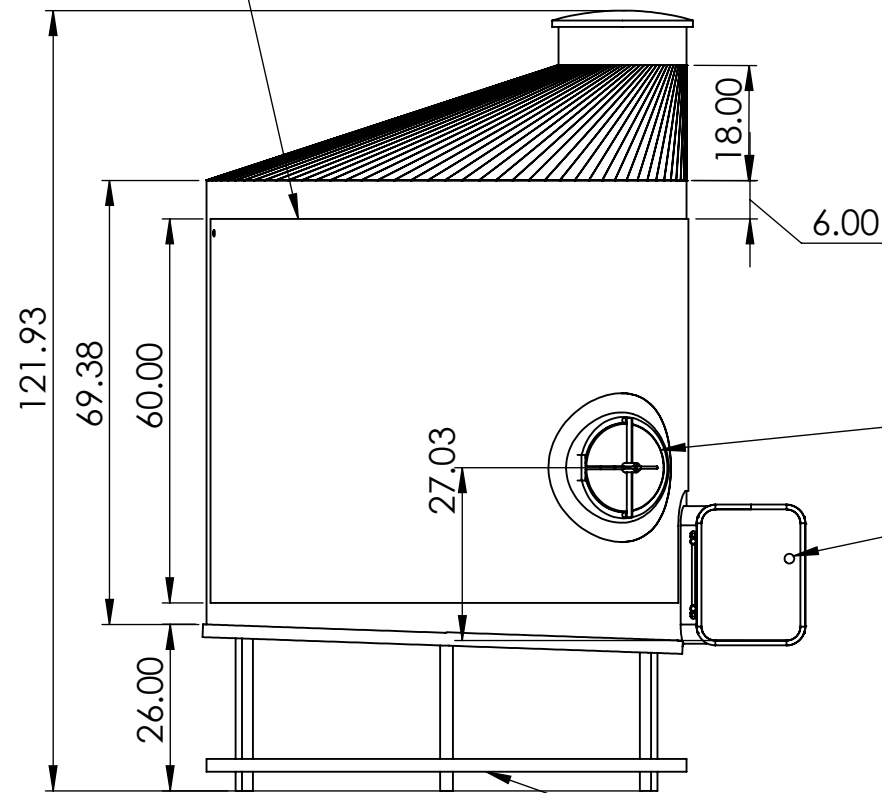
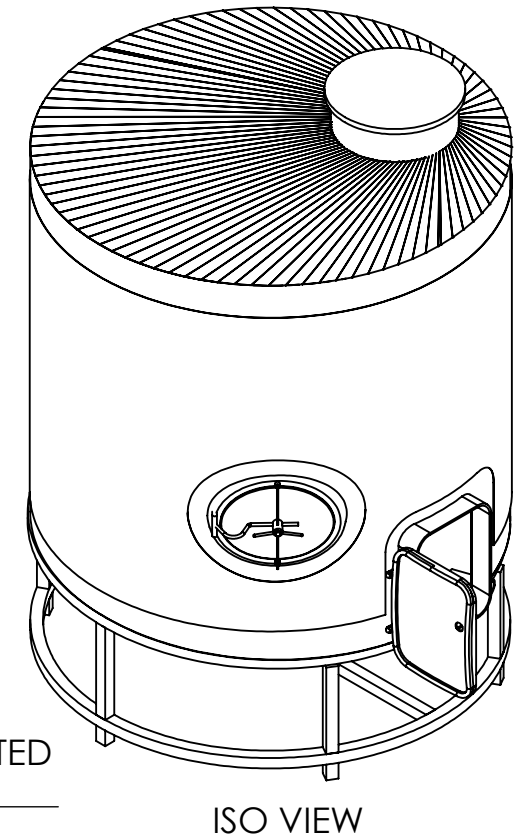
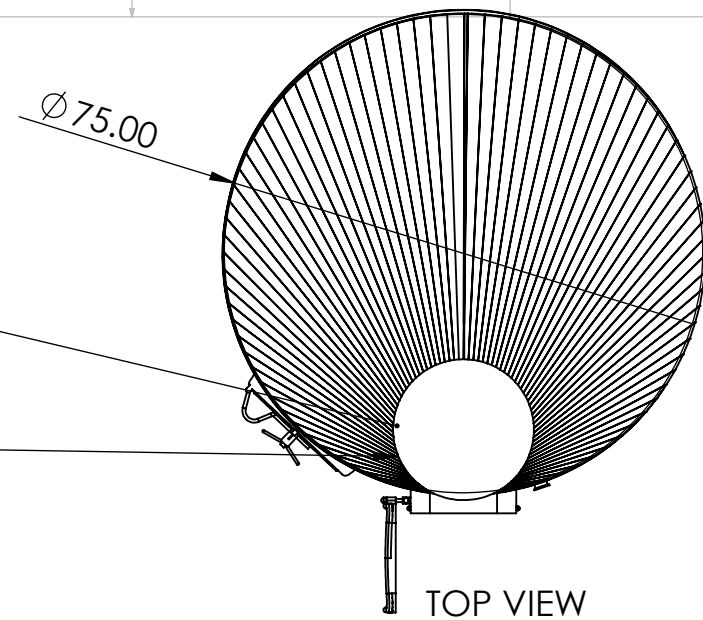

DUAL ACTION
MANWAY
Dual manway,
top inswing/outswing
manway for
racking access

Drainage sump and
ports are housed in a
precision engineered,
removable drain screen
inside the tank

SAMPLE PORT

OUTSWING OPENING
MANWAY

Lower square dump out
manway allows complete
cleanout of pomace
and wash debris

Option for either floor mount
or mounted on PKW's
proprietary ring stand.

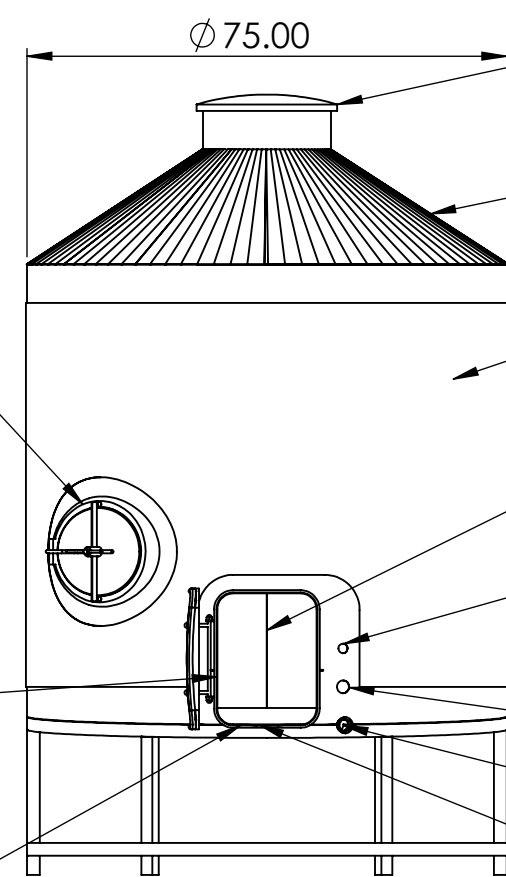

20" MANWAY

OFFSET TRUCATED
CONE

DIMPLE JACKET

Smooth 2-B interior finish,
blended and made sanitary
at all weldment

TEMP PORT
w/ protective temperature control shield

DIMPLE JACKET

RACKING PORT

SUMP DRAIN

SLOPED FLOOR



SIDE VIEW

FRONT VIEW

PORTLAND KETTLE WORKS

PROPRIETARY AND CONFIDENTIAL
THE INFORMATION CONTAINED IN THIS
DRAWING IS THE SOLE PROPERTY OF
PORTLAND KETTLE WORKS. ANY
REPRODUCTION IN PART OR AS A WHOLE
WITHOUT THE WRITTEN PERMISSION OF
PORTLAND KETTLE WORKS IS
PROHIBITED.

UNLESS OTHERWISE SPECIFIED:				NAME	DATE	TITLE:	
DIMENSIONS ARE IN INCHES	INTERPRET GEOMETRIC TOLERANCING PER: ASME	DRAWN	SF			WINE FERMENTER	
TOLERANCES:	MATERIAL	CHECKED				SIZE	PART NUMBER
FRACTIONAL: ± 1/8	FINISH	ENG APPR.				B	Wine Fermenter
ANGULAR: ±1°		MFG APPR.				SCALE: 1:50	WEIGHT:
TWO PLACE DECIMAL: ±0.01		Q.A.					SHEET 1 OF 1
THREE PLACE DECIMAL: ±0.005	DO NOT SCALE DRAWING						